

# RIVERCREST ESTATES

A PORTION OF THE S 1/4 SECTION 12, TOWNSHIP 10 NORTH, RANGE 28 EAST, W.M., FRANKLIN COUNTY, WASHINGTON.

## FRANKLIN COUNTY APPROVALS

THIS ANNEXED PLAT IS HEREBY APPROVED BY AND FOR THE COUNTY OF FRANKLIN, STATE OF WASHINGTON.

*Edul Chhet* 3-27-24  
CHAIRMAN, BOARD OF FRANKLIN COUNTY COMMISSIONERS DATE

*Mike Combs* 3/21/24  
CHAIRMAN, FRANKLIN COUNTY PLANNING COMMISSION DATE

ATTEST:  
*John Christensen* 3/18/2024  
FOR FRANKLIN COUNTY ENGINEER DATE

*Robin Mous* for *John Roseman* 3/18/24  
FRANKLIN COUNTY ASSESSOR DATE

## FRANKLIN COUNTY TREASURER APPROVAL

I HEREBY CERTIFY THAT THE TAXES AND ASSESSMENTS ON THE LAND DESCRIBED HEREON HAVE BEEN PAID TO AND INCLUDING THE YEAR 2023 A.D. TAX PARCEL NOS. 126190363 & 126190341.

*Edul Chhet* by *Joire Koelzer* 03/20/24  
FRANKLIN COUNTY TREASURER DATE

## BIG BEND ELECTRIC APPROVAL

THE UTILITY EASEMENTS ARE HEREBY APPROVED BY BIG BEND ELECTRIC COOPERATIVE.

*[Signature]* 11/7/2024  
BIG BEND ELECTRIC DATE

## IRRIGATION AND OWNERS CERTIFICATE

THE PROPERTY DESCRIBED HEREIN IS LOCATED WHOLLY OR IN PART WITHIN THE BOUNDARIES OF THE SOUTH COLUMBIA BASIN IRRIGATION DISTRICT (DISTRICT). THE DISTRICT HEREBY CERTIFIES THAT THE IRRIGATION EASEMENTS AND RIGHTS OF WAY SHOWN ON THE PLAT ARE ADEQUATE TO SERVE ALL LOTS LOCATED WITHIN THE PLAT AND OTHER ADJACENT LANDS WHICH ARE ENTITLED TO DISTRICT IRRIGATION WATER. A SEPARATE WRITTEN AGREEMENT FOR COMPLETED IRRIGATION FACILITIES HAS BEEN APPROVED; OR  $\Delta$  WILL NOT BE REQUIRED.

(CHECK ONE)  
THE OWNER ACKNOWLEDGES THE USE AND EXISTENCE OF IRRIGATION WATER AND DELIVERY SYSTEMS MUST COMPLY WITH ALL DISTRICT RULES AND REGULATIONS AND MAY CAUSE DAMAGE OR BE A HAZARD TO PROPERTY AND PERSONS. THE OWNER ASSUMES ALL RISK ASSOCIATED WITH THE USE AND DELIVERY OF IRRIGATION WATER AND HOLDS THE DISTRICT HARMLESS AND WAIVES ON BEHALF OF THEMSELVES AND THEIR SUCCESSORS IN INTERESTS ANY CLAIMS FOR DAMAGES OF ANY KIND AGAINST THE DISTRICT WHICH MAY BE CAUSED BY THE CONSTRUCTION, OPERATION, OR MAINTENANCE OF THE IRRIGATION FACILITIES; OR FROM THE DELIVERY, LEAKAGE, OR SEEPAGE OF WATER.

*Beau M. Gault* 15 Jan 2024  
SOUTH COLUMBIA BASIN IRRIGATION DISTRICT DATE

*[Signature]* 11/6/2024  
BUREAU OF RECLAMATION DATE

*[Signature]* 1-12-24  
OWNER DATE

## DEDICATION

WE, THE UNDERSIGNED, HEREBY CERTIFY THAT WE ARE THE OWNERS OF THE TRACT OF LAND DESCRIBED HEREON AND THAT WE HAVE CAUSED SAID LAND TO BE SURVEYED AND PLATTED INTO LOTS AND TRACTS AND THAT ALL STREETS, ROAD RIGHT-OF-WAY, UTILITY EASEMENTS, SHOWN HEREON ARE HEREBY DEDICATED TO THE PUBLIC AND THAT THIS SUBDIVISION SHALL HEREAFTER BE KNOWN AND DESIGNATED BY THE NAME RIVERCREST ESTATES.

*[Signature]*  
ROTSCH, LLC BY:

## ACKNOWLEDGMENTS

STATE OF WASHINGTON  
COUNTY OF FRANKLIN IS.S.

BY ITS PROPER OFFICERS THIS 12<sup>TH</sup> DAY OF JANUARY, 2024, ON THE DAY AND YEAR FIRST ABOVE WRITTEN, BEFORE ME PERSONALLY APPEARED:

*Jeff Kusav*  
TO ME KNOWN TO BE THE AREA MANAGER OF THE CORPORATION THAT EXECUTED THE WITHIN AND FOREGOING INSTRUMENT, AND ACKNOWLEDGED SAID INSTRUMENT TO BE THE FREE AND VOLUNTARY ACT AND DEED OF SAID CORPORATION, FOR THE USES AND PURPOSES THEREIN MENTIONED, AND ON OATH STATED THAT HE WAS AUTHORIZED TO EXECUTE SAID INSTRUMENT.

IN WITNESS WHEREOF, I HAVE HEREOF SET MY HAND AND OFFICIAL SEAL THE DAY AND YEAR FIRST ABOVE WRITTEN.

*Peter Harpster*  
PRINT NAME SIGN NAME

NOTARY PUBLIC IN AND FOR THE STATE OF WASHINGTON  
RESIDING AT PASCO, WA

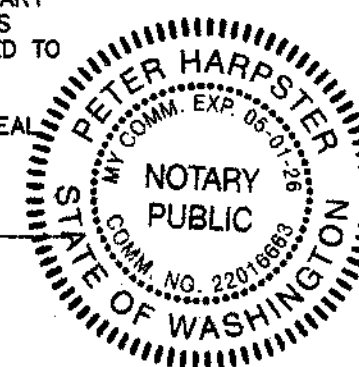

## LEGAL DESCRIPTION

PARCEL B (APN 126190341)

THAT PORTION OF LOT 3, SHORT PLAT NO. 88-01, ACCORDING TO THE SURVEY THEREOF RECORDED UNDER AUDITOR'S FILE NO. 458734, RECORDS OF FRANKLIN COUNTY, WASHINGTON, DESCRIBED AS FOLLOWS: COMMENCING AT THE SOUTHWEST CORNER OF SAID LOT 3, THENCE NORTH 09°28'19" WEST ALONG THE LINE THEREOF, AND ALONG THE EASTERLY MARGIN OF COLUMBIA RIVER ROAD, A DISTANCE OF 10.45 FEET TO THE TRUE POINT OF BEGINNING; THENCE ALONG THE WESTERLY LINE THEREOF WITH THE FOLLOWING COURSES: NORTH 09°28'19" WEST A DISTANCE OF 50.31 FEET; THENCE SOUTH 89°55'52" EAST A DISTANCE OF 80.10 FEET TO THE BEGINNING OF A CURVE CONCAVE TO THE NORTHWEST HAVING A RADIUS OF 279.71 FEET; THENCE NORTHEASTERLY ALONG THE CURVE THROUGH A CENTRAL ANGLE OF 46°10'01" A DISTANCE OF 225.38 FEET; THENCE NORTH 43°54'07" EAST A DISTANCE OF 9.68 FEET; THENCE NORTH 09°28'26" WEST A DISTANCE OF 649.93 FEET TO THE BEGINNING OF A CURVE CONCAVE TO THE NORTHEAST HAVING A RADIUS OF 5399.58 FEET; THENCE NORTHWESTERLY ALONG THE ARC OF SAID CURVE THROUGH A CENTRAL ANGLE OF 4°59'05" A DISTANCE OF 496.76 FEET; THENCE NORTH 04°30'21" WEST A DISTANCE OF 743.69 FEET TO THE NORTHWEST CORNER OF SAID LOT; THENCE SOUTH 89°55'53" EAST, ALONG THE NORTH LINE OF SAID LOT, A DISTANCE OF 220.43 FEET; THENCE LEAVING SAID LINE, SOUTH 22°05'31" EAST A DISTANCE OF 276.91 FEET TO THE BEGINNING OF A NON-TANGENT CURVE CONCAVE TO THE SOUTHEAST HAVING A RADIUS OF 55.00 FEET AND FROM WHICH POINT THE CHORD BEARS NORTH 74°16'19" EAST A DISTANCE OF 23.19 FEET; THENCE NORTHEASTERLY ALONG THE ARC OF SAID CURVE THROUGH A CENTRAL ANGLE OF 24°20'44" A DISTANCE OF 23.37 FEET; THENCE SOUTH 08°46'16" EAST A DISTANCE OF 1441.07 FEET TO THE BEGINNING OF A CURVE CONCAVE TO THE NORTHWEST HAVING A RADIUS OF 180.00 FEET; THENCE SOUTHWESTERLY ALONG THE ARC OF SAID CURVE THROUGH A CENTRAL ANGLE OF 74°16'19" EAST A DISTANCE OF 233.57 FEET; THENCE SOUTH 65°30'41" WEST A DISTANCE OF 203.92 FEET TO THE BEGINNING OF A CURVE CONCAVE TO THE NORTHWEST HAVING A RADIUS OF 230.00 FEET; THENCE SOUTHWESTERLY ALONG THE ARC OF SAID CURVE THROUGH A CENTRAL ANGLE OF 20°00'00" A DISTANCE OF 80.29 FEET; THENCE SOUTH 85°30'41" WEST A DISTANCE OF 258.82 FEET TO THE POINT OF BEGINNING.

(ALSO KNOWN AS PARCEL B OF RECORD SURVEY RECORDED UNDER AUDITOR'S FILE NO. 1954333.)

PARCEL C (APN 126190363)  
LOT 4 SHORT PLAT NO. 88-01, ACCORDING TO THE SURVEY THEREOF RECORDED UNDER AUDITOR'S FILE NO. 458734, RECORDS OF FRANKLIN COUNTY, WASHINGTON.

## BENTON FRANKLIN HEALTH DISTRICT APPROVAL

THIS PLAT IS HEREBY APPROVED BY AND FOR THE BENTON-FRANKLIN HEALTH DISTRICT FOR THE COUNTY OF FRANKLIN, STATE OF WASHINGTON.

*[Signature]* 3/15/2024  
BENTON-FRANKLIN HEALTH DISTRICT DATE

## BENTON FRANKLIN HEALTH DISTRICT NOTES

1. THIS PLAT APPEARS TO HAVE SUITABLE CONDITIONS FOR THE USE OF ON-SITE SEWAGE DISPOSAL. HOWEVER, BECAUSE OF THE TESTING METHODS USED, WE HAVE NO WAY OF DETERMINING WHETHER EACH LOT CAN COMPLY WITH BENTON-FRANKLIN DEPARTMENT RULES AND REGULATIONS AT THE TIME OF PERMIT ISSUANCE.
2. FURTHER, BE ADVISED THIS DEPARTMENT'S APPROVAL OF ANY LOT WITHIN THIS PLAT FOR THE USE OF ON-SITE SEWAGE DISPOSAL SYSTEMS MAY BE CONTINGENT UPON THAT LOT PASSING ADDITIONAL SOIL INSPECTION/PERCOLATION TEST, AND/OR OTHER REQUIREMENTS AT A LATER DATE.
3. THE LOTS WITHIN THIS PLAT MAY HAVE SPECIFIC LIMITATIONS AND/OR RESTRICTIONS FOR THE PLACEMENT OF ON-SITE SEWAGE DISPOSAL SYSTEMS. THE BENTON-FRANKLIN HEALTH DEPARTMENT SHOULD BE CONTACTED FOR FURTHER INFORMATION. THESE LOTS HAVE SPECIFIC LIMITATIONS FOR THE PLACEMENT OF SEWAGE DISPOSAL SYSTEMS. ANY ON-SITE SEWAGE DISPOSAL SYSTEM TO BE PERMITTED ON THESE LOTS MUST MEET A MINIMUM OF 18" DEPTH LEVEL. THE BENTON-FRANKLIN HEALTH DEPARTMENT SHOULD BE CONTACTED FOR FURTHER INFORMATION.

## FRANKLIN COUNTY REQUIRED NOTES

1. ALL NEW APPROACHES TO COUNTY ROADS WILL REQUIRE AN APPROACH PERMIT AT THE TIME OF BUILDING PERMIT APPLICATION. A MITIGATION FEE IS REQUIRED AND WILL BE COLLECTED AT THE TIME OF ROAD APPROACH PERMIT ISSUANCE.
2. NO LOT WITHIN THIS SUBDIVISION SHALL HAVE DIRECT ACCESS TO COLUMBIA RIVER ROAD.
3. LOT OWNERS SHALL AGREE TO PARTICIPATE IN ANY FUTURE L.I.D./R.I.D.'S FOR ROADS, DRAINAGE, CURB & GUTTERS, STREETLIGHTS, STORM SEWERS, WATER AND/OR SANITARY SEWERS.
4. LOT OWNERS SHALL BE RESPONSIBLE FOR THE MAINTENANCE OF DRAINAGE DITCHES OR SWALES PER THE DESIGN AS SHOWN ON THE ROAD CONSTRUCTION PLANS FOR THIS DEVELOPMENT, UNLESS THEY ARE NO LONGER NECESSARY DUE TO AN ALTERNATE DRAINAGE SYSTEM BEING INSTALLED.
5. ALL LOT OWNERS SHALL PROVIDE LANDSCAPING WITHIN THE UNIMPROVED PORTION OF THE RIGHT OF WAY BETWEEN THE PROPERTY LINE AND THE EDGE OF PAVEMENT AND/OR CURB. THIS SHALL CONSIST OF GRASS/LAWN, RIVER ROCK, BASALT ROCK, GRAVEL OR OTHER TRADITIONAL RESIDENTIAL LANDSCAPING MATERIAL. MAINTENANCE OF THE LANDSCAPING IS THE REQUIREMENT OF EACH LAND OWNER.
6. IRRIGATION REQUIREMENTS: ALL LOTS WITHIN THIS DEVELOPMENT SHALL AT ALL TIMES HAVE AN OUTSIDE IRRIGATION SOURCE (SEPARATE FROM INDIVIDUAL SINGLE-FAMILY WELLS) PROVIDED TO THEM FOR THE LIFE OF THIS DEVELOPMENT.
7. COLLECTIVELY NO MORE THAN 5,000 GALLONS OF WATER PER DAY, INCLUDING IRRIGATION PURPOSES, MAY BE USED FROM EXEMPT WELLS IN THIS DEVELOPMENT.
8. DURING CONSTRUCTION ON EACH PROPERTY, ALL CONSTRUCTION DEBRIS SHALL BE MAINTAINED ON-SITE AND PROPERLY DISPOSED OF. DUST CONTROL MEASURES INCLUDING AN ADEQUATE WATER SUPPLY SHALL BE PROVIDED.
9. ALL LOT OWNERS SHALL PROVIDE LANDSCAPING WITHIN THE UNIMPROVED PORTION OF THE RIGHT OF WAY BETWEEN THE PROPERTY LINE AND THE EDGE OF PAVEMENT AND/OR CURB. THIS SHALL CONSIST OF GRASS/LAWN, RIVER ROCK, BASALT ROCK, GRAVEL OR OTHER TRADITIONAL RESIDENTIAL LANDSCAPING MATERIAL. MAINTENANCE OF THE LANDSCAPING IS THE REQUIREMENT OF EACH INDIVIDUAL LOT OWNER.
10. ALL LOTS IN THE DEVELOPMENT ARE SUBJECT TO PARK DEDICATION FEES (\$50.00 PER NEW LOT/EXPECTED NEW DWELLING UNIT). THESE FEES SHALL BE PAID PRIOR TO BUILDING PERMIT ISSUANCE FOR NEW HOME ON EACH LOT.
11. THIS PROPERTY IS LOCATED IN A FRANKLIN COUNTY RIGHT TO FARM AREA. THE FRANKLIN COUNTY RIGHT TO FARM ORDINANCE, AS AMENDED, SHALL APPLY TO ACTIVITIES IN THIS AREA.

## FRANKLIN COUNTY PUBLIC WORKS NOTE

THE CONTRACTORS SHALL WARRANT ALL COUNTY-WORK-COMPLETED-WITH-CONSTRUCTION OF THIS PROJECT FOR 72 MONTHS AFTER FINAL ACCEPTANCE OF COMPLETED WORK.

## BENTON FRANKLIN HEALTH DISTRICT ADDITIONAL NOTE

FURTHER SUBDIVISION OF THE PROPERTY, UNTIL SERVED BY A RECOGNIZED SEWER UTILITY IS PROHIBITED.

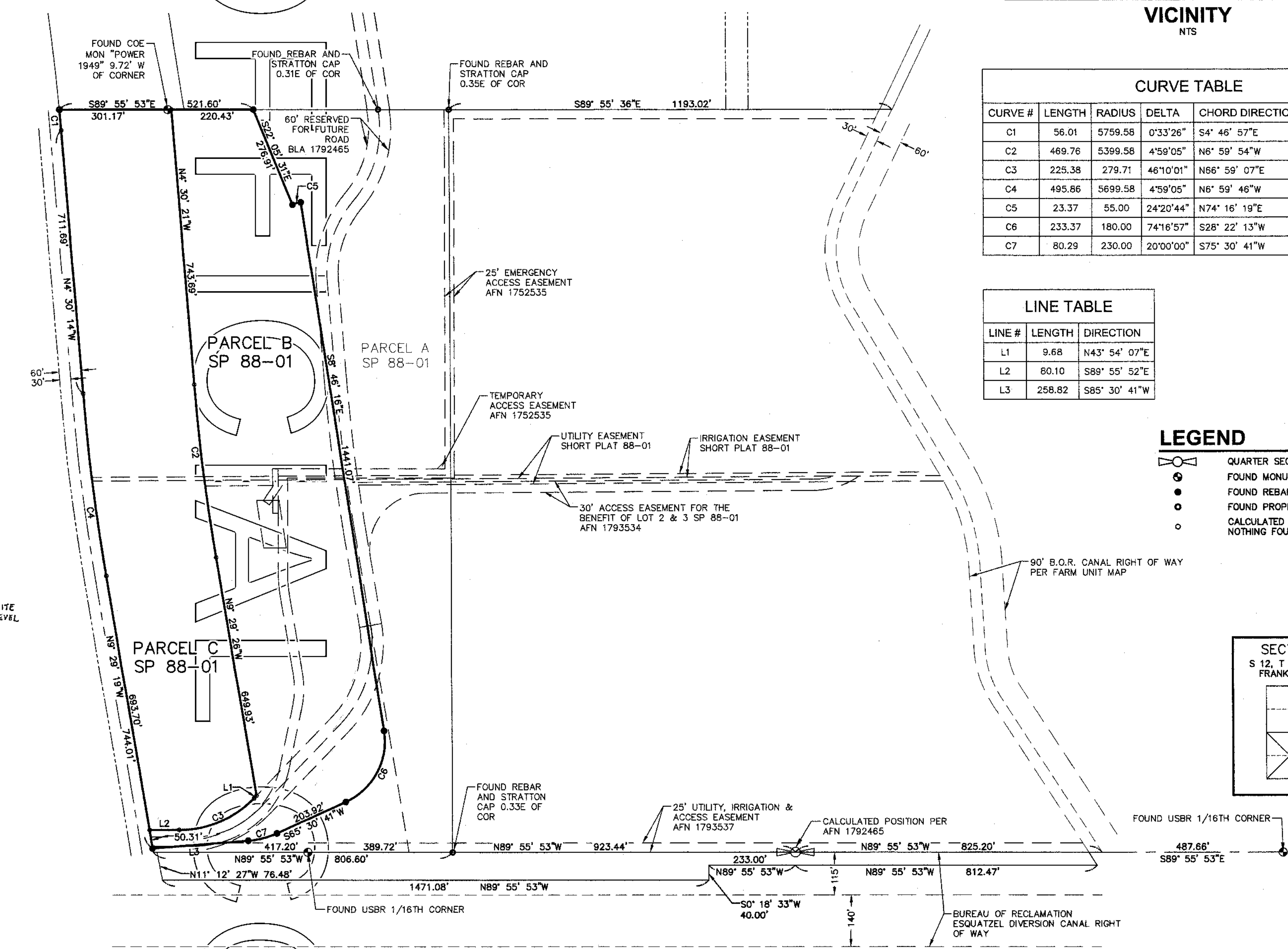

### CURVE TABLE

CURVE #	LENGTH	RADIUS	DELTA	CHORD DIRECTION	CHORD LENGTH
C1	56.01	5759.58	0°33'26"	S4° 46' 57"E	56.01
C2	469.76	5399.58	4°59'05"	N6° 59' 54"W	469.61
C3	225.38	279.71	46°10'01"	N66° 59' 07"E	219.33
C4	495.86	5699.58	4°59'05"	N6° 59' 46"W	495.71
C5	23.37	55.00	24°20'44"	N74° 16' 19"E	23.19
C6	233.37	180.00	74°16'57"	S28° 22' 13"W	217.36
C7	80.29	230.00	20°00'00"	S75° 30' 41"W	79.88

### LINE TABLE

LINE #	LENGTH	DIRECTION
L1	9.68	N43° 54' 07"E
L2	80.10	S89° 55' 52"E
L3	258.82	S85° 30' 41"W

### LEGEND

- QUARTER SECTION CORNER
- FOUND MONUMENT AS NOTED
- FOUND REBAR AND CAP LS 38480
- FOUND PROPERTY CORNER AS NOTED
- CALCULATED POINT
- NOTHING FOUND OR SET

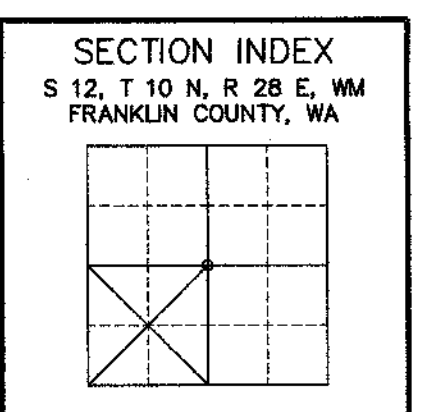

## AUDITOR'S CERTIFICATE

FILED FOR RECORD THIS 27 DAY OF March, 2024  
AT 07 MINUTES PAST 10 AM/PM, AT THE REQUEST OF  
AHBL, INC., UNDER AUDITOR'S FEE NO.  
IN VOLUME D OF SURVEYS AT PAGE 307  
INDEX/RECORD SURVEY NO. 1984228  
*[Signature]*  
DEPUTY FRANKLIN COUNTY AUDITOR

## SURVEYOR'S CERTIFICATE

I JOHN W. BECKER, REGISTERED AS A PROFESSIONAL LAND SURVEYOR BY THE STATE OF WASHINGTON HEREBY CERTIFY THAT THIS PLAT IS A TRUE AND CORRECT REPRESENTATION OF THE LANDS ACTUALLY SURVEYED AND DESCRIBED HEREIN AND LOCATED IN A PORTION OF SECTION 12, T10N, R28E, W.M.  
*[Signature]*  
JOHN W. BECKER, PLS REGISTRATION NO. 38480 1-11-2024

DWN. BY	DATE
FSS	12/21/23
CHKD. BY	JOB NO.
JB	2190873



**RIVERCREST ESTATES**  
 A PORTION OF THE S 1/4 SECTION 12, TOWNSHIP 10 NORTH, RANGE 28 EAST, W.M.,  
 FRANKLIN COUNTY, WASHINGTON.

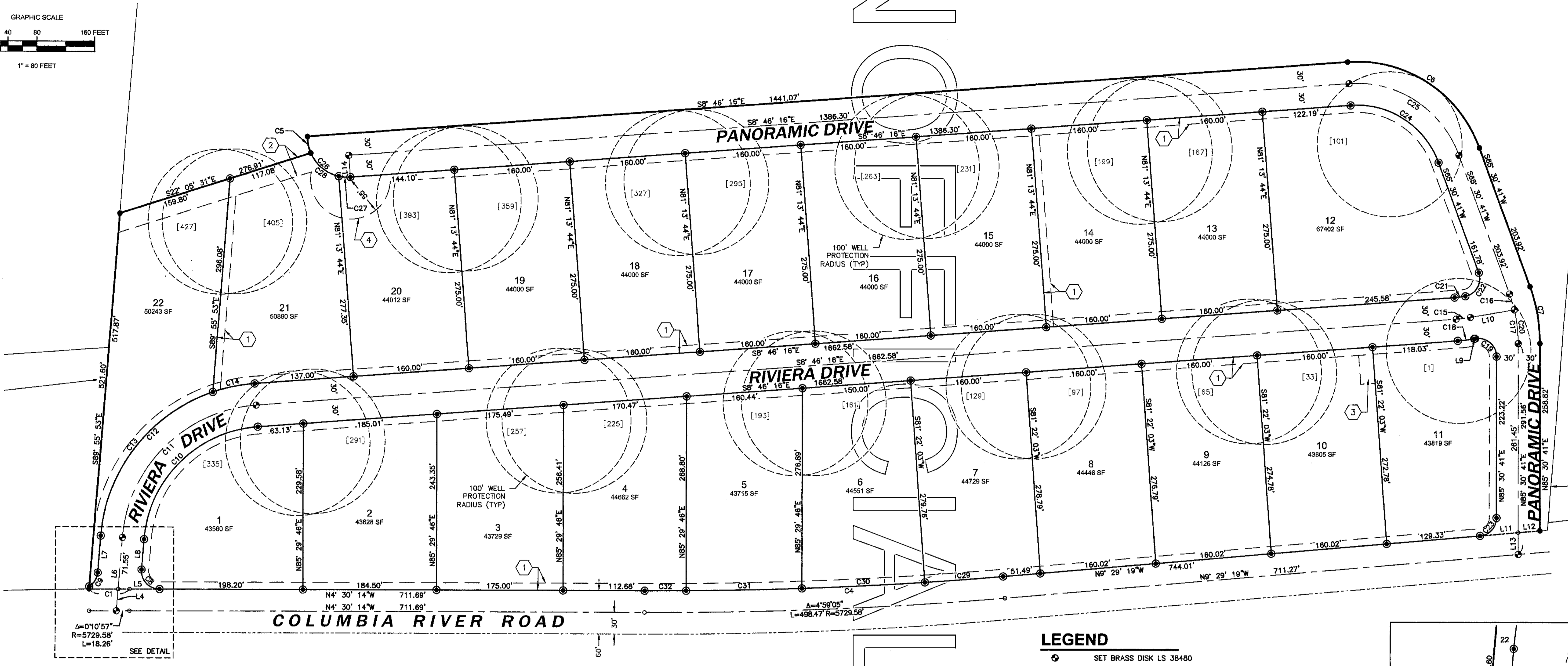
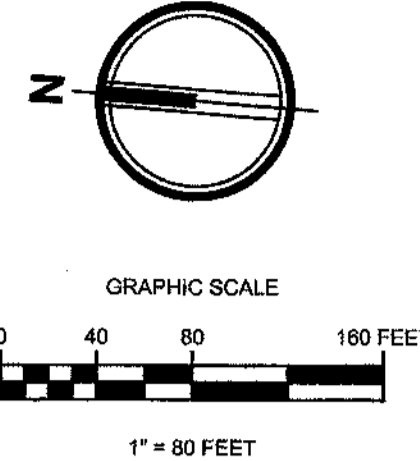

**LEGEND**

- SET BRASS DISK LS 38480
- ⊙ SET REBAR AND CAP LS 38480
- ⬡ NEW EASEMENT (SEE TABLE)
- FOUND REBAR AND CAP LS 38480
- FOUND PROPERTY CORNER AS NOTED
- CALCULATED POINT
- NOTHING FOUND OR SET

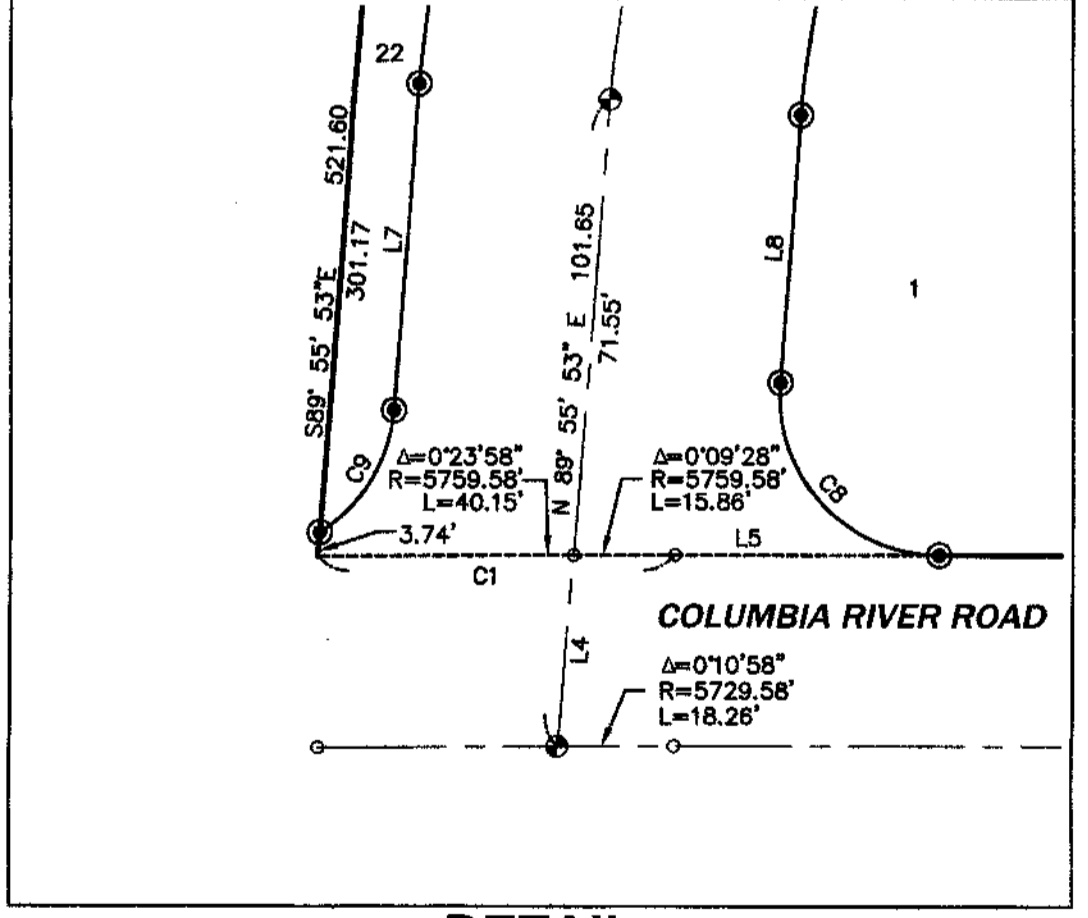

DETAIL  
NTS

CURVE TABLE					
CURVE #	LENGTH	RADIUS	DELTA	CHORD DIRECTION	CHORD LENGTH
C1	56.01	5759.58	0°33'26"	S4° 46' 57"E	56.01
C2	469.76	5399.58	4°59'05"	N6° 59' 54"W	469.61
C4	495.86	5699.58	4°59'05"	N8° 59' 46"W	495.71
C5	23.37	55.00	24°20'44"	N74° 16' 19"E	23.19
C6	233.37	180.00	74°16'57"	S28° 22' 13"W	217.36
C7	80.29	230.00	20°00'00"	S75° 30' 41"W	79.88
C8	41.26	25.00	94°34'20"	N42° 46' 56"E	36.74
C9	23.18	25.00	53°07'47"	N63° 22' 00"W	22.36
C10	240.81	170.00	81°09'37"	S49° 21' 05"E	221.17
C11	283.30	200.00	81°09'37"	S49° 21' 05"E	280.20
C12	325.80	230.00	81°09'37"	N49° 21' 05"W	299.24
C13	286.65	230.00	66°25'37"	N56° 43' 05"W	251.97
C14	59.14	230.00	14°44'01"	N16° 08' 16"W	58.98
C15	19.96	200.00	5°43'03"	S11° 37' 47"E	19.95
C16	22.76	200.00	6°31'11"	N68° 46' 17"E	22.75
C17	47.06	200.00	13°28'49"	N78° 46' 17"E	46.95
C18	22.95	230.00	5°43'03"	S11° 37' 47"E	22.94
C19	44.13	25.00	101°08'06"	S34° 56' 38"W	38.62
C20	69.81	200.00	20°00'00"	S75° 30' 41"W	69.46
C21	15.01	170.00	5°03'34"	N11° 18' 03"W	15.01

CURVE TABLE					
CURVE #	LENGTH	RADIUS	DELTA	CHORD DIRECTION	CHORD LENGTH
C22	42.42	25.00	97°13'08"	S64° 48' 14"E	37.51
C23	37.09	25.00	84°59'59"	N51° 59' 19"W	33.78
C24	155.58	120.00	74°16'57"	N28° 22' 13"E	144.91
C25	194.47	150.00	74°16'57"	S28° 22' 13"W	181.13
C26	91.40	55.00	95°12'57"	S38° 59' 13"W	81.24
C27	68.03	55.00	70°52'13"	N26° 39' 50"E	63.76
C28	51.90	55.00	54°04'17"	S35° 03' 48"W	50.00
C29	108.52	5699.58	1°05'27"	N8° 56' 35"W	108.51
C30	169.97	5699.58	1°42'31"	N7° 32' 36"W	169.96
C31	160.05	5699.58	1°36'32"	N5° 53' 04"W	160.05
C32	57.32	5699.58	0°34'35"	N4° 47' 31"W	57.32

LINE TABLE		
LINE #	LENGTH	DIRECTION
L4	30.10	S89° 55' 53"E
L5	41.32	N4° 30' 14"W
L6	101.65	S89° 55' 53"E
L7	51.26	N89° 55' 53"W
L8	42.05	S89° 55' 53"E
L9	1.09	S14° 29' 19"E

LINE TABLE		
LINE #	LENGTH	DIRECTION
L10	61.53	S14° 29' 19"E
L11	53.02	S92° 29' 19"E
L12	30.11	S9° 29' 19"E
L13	30.11	N85° 30' 41"E
L14	33.00	S81° 13' 45"W

**EQUIPMENT USED**

3" TOTAL STATION UTILIZING STANDARD FIELD TRAVERSE METHODS FOR CONTROL AND STAKING.

**BASIS OF BEARING**

NAD 1983 WASHINGTON STATE PLANE SOUTH PROJECTION, BASED ON GPS OBSERVATIONS USING WSRN AND GEOID 2012A. UNITS OF MEASUREMENT ARE US SURVEY FEET.

**NEW EASEMENT TABLE**

1. 10' UTILITY EASEMENT
2. 25' ACCESS AND UTILITY EASEMENT TO SERVE LOT 22
3. 20' X 40' FIRE SUPPRESSION TANK EASEMENT
4. 55' RADIUS ACCESS AND UTILITY EASEMENT

**AUDITOR'S CERTIFICATE**

FILED FOR RECORD THIS 27 DAY OF March, 2024  
 AT 07 MINUTES PAST 10 AM/PM, AT THE REQUEST OF  
 AHBL, INC., UNDER AUDITOR'S FEE NO. \_\_\_\_\_  
 IN VOLUME D OF SURVEYS AT PAGE 708  
 INDEX/RECORD SURVEY NO. 1984228

*Matt Beaton*  
 FRANKLIN COUNTY AUDITOR

DWN. BY DATE  
 FSS 03/05/24  
 CHKD. BY JOB NO.  
 JB 2190873



**AHBL**  
 TACOMA · SEATTLE · SPOKANE · TRI-CITIES  
 5804 Road 90, Suite H Pasco, WA 99301  
 509.380.5883 TEL. 253.383.2572 FAX www.ahbl.com WEB

# RIVERCREST ESTATES

A PORTION OF THE S 1/4 SECTION 12, TOWNSHIP 10 NORTH, RANGE 28 EAST, W.M.,  
FRANKLIN COUNTY, WASHINGTON.

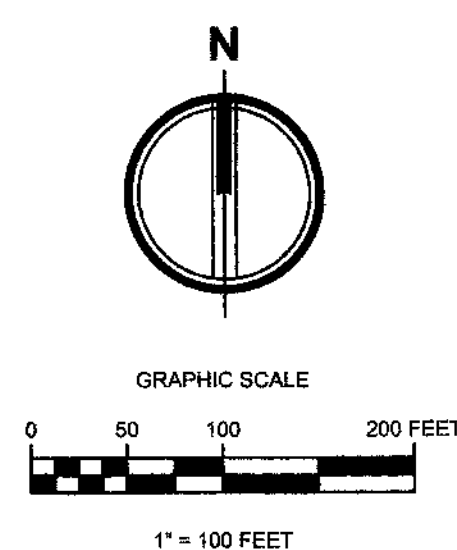

COLUMBIA RIVER ROAD

PARCEL C  
SP 88-01

PARCEL B  
SP 88-01

PARCEL A  
SP 88-01

60' RESERVED FOR FUTURE ROAD  
BLA 1792465

15' TEMPORARY  
ACCESS EASEMENT  
AFN 1752535

TEMPORARY ACCESS  
EASEMENT AFN 1752535

25' EMERGENCY  
ACCESS EASEMENT  
AFN 1752535

UTILITY EASEMENT  
SHORT PLAT 88-01

30' ACCESS EASEMENT FOR THE  
BENEFIT OF LOT 2 & 3 SP 88-01  
AFN 1793534

60' ROAD EASEMENT  
AFN 272680

30' EMERGENCY  
ACCESS EASEMENT  
AFN 1752535

25' UTILITY, IRRIGATION  
& ACCESS EASEMENT  
AFN 1793537

### EASEMENT NOTE

THOSE PORTIONS OF EXISTING EASEMENTS WITHIN PLAT BOUNDARY, AS  
HATCHED HEREON, TO BE VACATED UPON APPROVAL OF THIS PLAT.

### AUDITOR'S CERTIFICATE

FILED FOR RECORD THIS 1 DAY OF March, 2024  
AT 07 MINUTES PAST 10 AM/PM, AT THE REQUEST OF  
AHBL, INC., UNDER AUDITOR'S FEE NO. \_\_\_\_\_  
IN VOLUME D OF SURVEYS, AT PAGE 709  
INDEX/RECORD SURVEY NO. 1984228

  
DEPUTY Matt Beaton  
FRANKLIN COUNTY AUDITOR

DWN. BY \_\_\_\_\_ DATE \_\_\_\_\_  
FSS 03/05/24  
CHKD. BY \_\_\_\_\_ JOB NO. \_\_\_\_\_  
JB 2190873

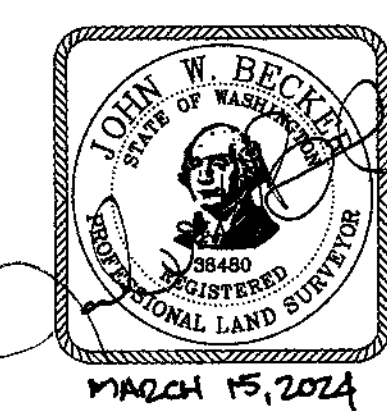

# RIVERCREST ESTATES

A PORTION OF THE S 1/4 SECTION 12, TOWNSHIP 10 NORTH, RANGE 28 EAST, W.M.,  
FRANKLIN COUNTY, WASHINGTON.

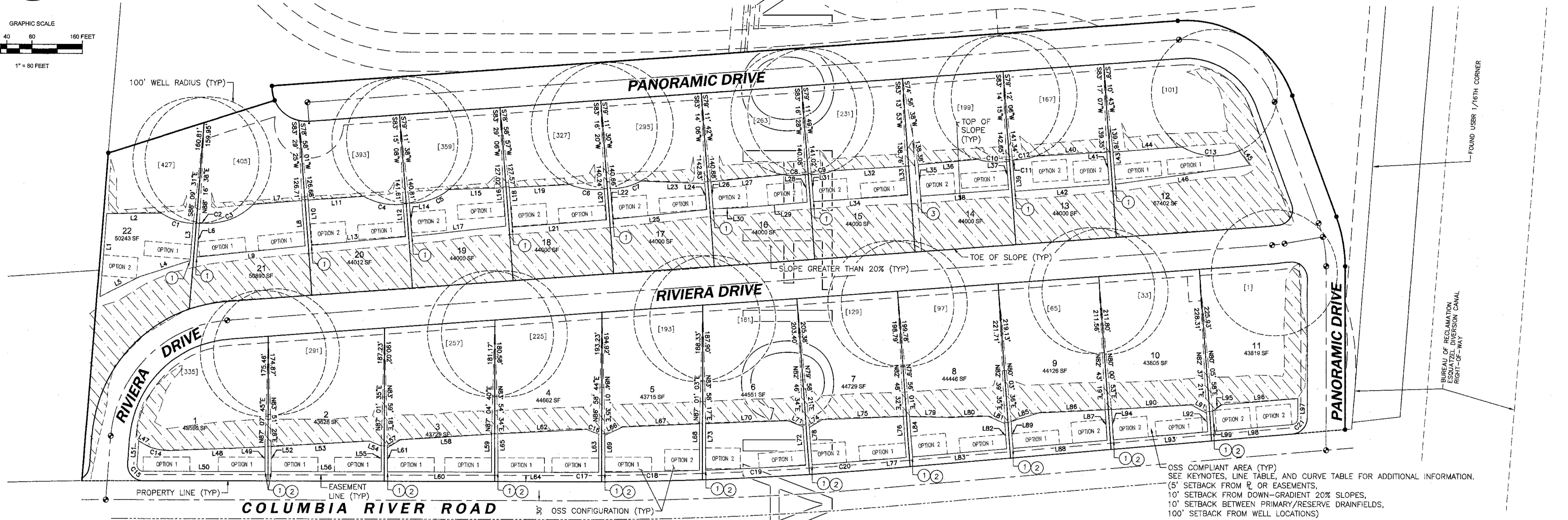
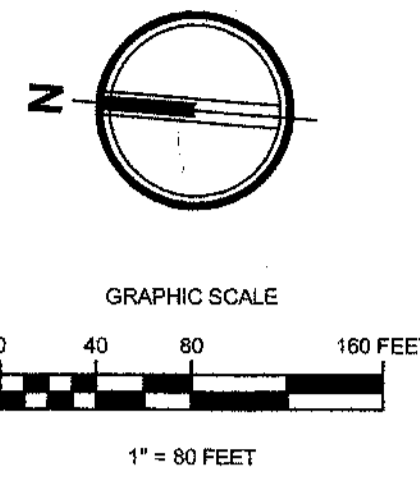

OSS COMPLIANT AREA (TYP)  
SEE KEYNOTES, LINE TABLE, AND CURVE TABLE FOR ADDITIONAL INFORMATION.  
5' SETBACK FROM E OR EASEMENTS,  
10' SETBACK FROM DOWN-GRADIENT 20% SLOPES,  
10' SETBACK BETWEEN PRIMARY/RESERVE DRAINFIELDS,  
100' SETBACK FROM WELL LOCATIONS)

### BENTON-FRANKLIN HEALTH DISTRICT NOTES

- ALL LOTS WITHIN THIS SUBDIVISION ARE LIMITED TO A MAXIMUM OF 4 BEDROOMS PER LOT.
- THE DRAINFIELD FOR ANY ON-SITE SEWAGE DISPOSAL SYSTEM MUST BE LOCATED WITHIN THE AREA SO DESIGNATED AND SHOWN ON THIS PAGE OF THE PLAT.
- ADDITIONAL NOTES, REQUIREMENTS, AND RESTRICTIONS ARE PROVIDED ON SHEET 1 OF THIS FINAL PLAT.

### LEGEND

- SET BRASS DISK LS 38480
- SET REBAR AND CAP LS 38480
- KEYNOTE (SEE TABLE)
- FOUND REBAR AND CAP LS 38480
- FOUND PROPERTY CORNER AS NOTED

### OSS DRAINFIELD INFO

- ASSUMPTIONS:**
- TYPE 1 SOILS
  - 4 BEDROOM HOUSE
- CALCULATIONS:**
- 165 SF DRAINFIELD AREA PER BEDROOM = 660 SF
  - 660 SF / 3 LF WIDE DISPERSION TRENCH = 220 LF PIPE
  - 220 LF PIPE = 3 LINES @ 74 LF (OPTION 1), OR 4 LINES @ 55 LF (OPTION 2)

- POSITIONING:**
- DRAINFIELD LOCATIONS SHOWN ARE CONCEPTUAL TO ASSIST WITH FINAL OSS DESIGN. PRIMARY AND RESERVE DRAINFIELDS MUST:
- UTILIZE DRAINFIELD OPTION 1 OR OPTION 2,
  - MAINTAIN 10' MINIMUM SEPARATION FROM EACH OTHER, AND
  - BE CONFIGURED TO FIT ENTIRELY WITHIN THE OSS COMPLIANT AREA DEPICTED

### OSS DRAINFIELD OPTIONS (NTS)

#### TYPE 1 SOILS

##### OPTION 1

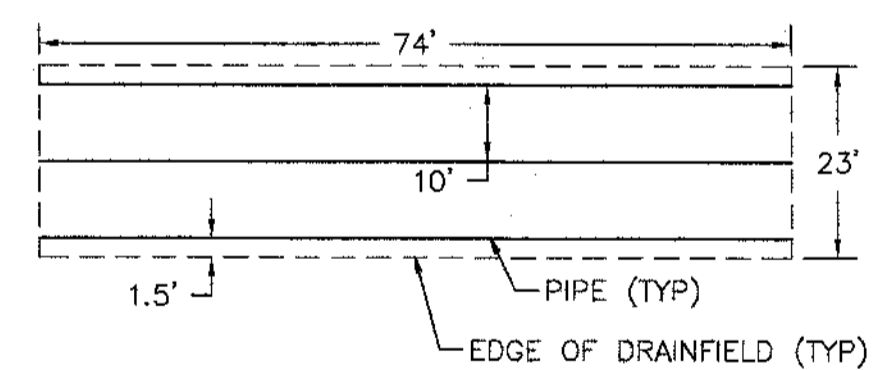

##### OPTION 2

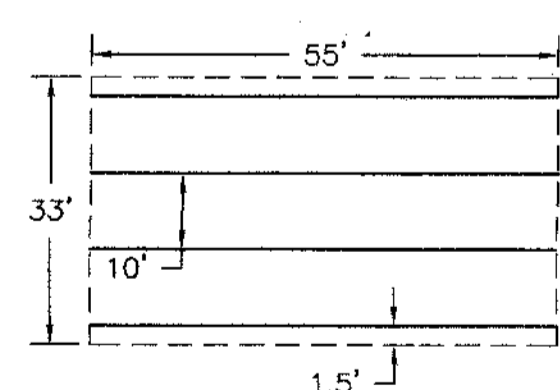

### KEYNOTES

- ① 5' FROM SHARED PROPERTY LINE
- ② 15' FROM COLUMBIA RIVER ROAD PROPERTY LINE
- ③ 15' FROM SHARED PROPERTY LINE

DWN. BY DATE  
FSS 03/14/24  
CHKD. BY JOB NO.  
JB 2190873

### AUDITOR'S CERTIFICATE

FILED FOR RECORD THIS 27 DAY OF March, 2024  
AT 07 MINUTES PAST 10 AM/PM, AT THE REQUEST OF  
AHBL, INC., UNDER AUDITOR'S FEE NO. \_\_\_\_\_  
IN VOLUME D OF Plat AT PAGE 710  
INDEX/RECORD SURVEY NO. 1984228

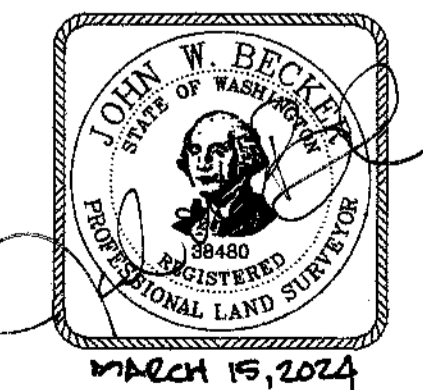

LINE #	LENGTH	DIRECTION
L1	132.07	N89° 55' 53"W
L2	86.30	N5° 14' 25"W
L3	58.99	S89° 54' 27"E
L4	83.59	S22° 14' 23"E
L5	70.99	S31° 11' 37"E
L6	53.44	S89° 55' 53"E
L7	77.41	S9° 12' 18"E
L8	72.11	S81° 13' 44"W
L9	172.92	N10° 29' 20"W
L10	71.88	S81° 13' 44"W
L11	88.71	N8° 27' 56"W
L12	51.68	N81° 13' 44"E
L13	150.03	S9° 52' 52"E
L14	52.55	S81° 13' 44"W
L15	85.72	N6° 30' 41"W
L16	60.85	N81° 13' 44"E
L17	150.10	S10° 52' 18"E
L18	62.74	S81° 13' 44"W
L19	96.18	N7° 36' 13"W
L20	49.13	N81° 13' 44"E

LINE #	LENGTH	DIRECTION
L21	150.00	S9° 07' 40"E
L22	48.44	S81° 13' 44"W
L23	101.87	N2° 41' 31"W
L24	41.50	N81° 13' 44"E
L25	150.08	S10° 35' 48"E
L26	43.04	S81° 13' 44"W
L27	114.90	N10° 26' 01"W
L28	43.93	N81° 13' 44"E
L29	105.24	S9° 26' 48"E
L30	44.79	S7° 04' 06"E
L31	42.91	S81° 13' 44"W
L32	115.02	N7° 55' 22"W
L33	45.51	N81° 19' 11"E
L34	150.08	S8° 38' 17"E
L35	50.01	S81° 13' 44"W
L36	94.83	N9° 50' 41"W
L37	44.42	N81° 13' 44"E
L38	139.85	S9° 00' 18"E
L39	49.35	S81° 13' 44"W
L40	113.51	N7° 50' 35"W

LINE #	LENGTH	DIRECTION
L41	50.83	N81° 13' 44"E
L42	150.00	S8° 57' 59"E
L43	51.09	N81° 13' 44"E
L44	110.06	S8° 50' 57"E
L45	28.56	S50° 05' 24"W
L46	215.38	N12° 34' 37"W
L47	10.77	N24° 47' 34"E
L48	151.23	N6° 47' 33"W
L49	39.19	N85° 29' 46"E
L50	193.20	S4° 30' 14"E
L51	37.28	N89° 55' 53"W
L52	39.78	S85° 29' 46"W
L53	156.18	N7° 49' 51"W
L54	20.10	N17° 53' 56"E
L55	41.18	N85° 29' 46"E
L56	174.50	S4° 30' 14"E
L57	23.93	S35° 09' 09"E
L58	144.87	S8° 15' 00"E
L59	60.31	S85° 29' 46"W
L60	165.00	N4° 30' 14"W

LINE #	LENGTH	DIRECTION
L61	38.40	N85° 29' 46"E
L62	141.89	S7° 28' 37"E
L63	60.69	S85° 29' 46"W
L64	107.68	N4° 30' 14"W
L65	60.90	N85° 29' 46"E
L66	30.76	S29° 40' 33"E
L67	122.28	S7° 03' 35"E
L68	73.80	S85° 29' 46"W
L69	58.89	N85° 29' 46"E
L70	130.07	S6° 52' 32"E
L71	26.09	S16° 59' 56"W
L72	61.40	S81° 22' 03"W
L73	73.85	N85° 29' 46"E
L74	24.03	S35° 47' 11"E
L75	128.68	S6° 51' 35"E
L76	65.14	S81° 22' 03"W
L77	46.72	N9° 29' 19"W
L78	59.46	N81° 22' 03"E
L79	65.75	S3° 27' 47"E
L80	58.53	S6° 31' 55"E

LINE #	LENGTH	DIRECTION
L81	29.31	S18° 44' 02"W
L82	40.21	S81° 22' 03"W
L83	150.02	N9° 29' 19"W
L84	63.99	N81° 22' 03"E
L85	45.88	S21° 57' 36"E
L86	105.39	S7° 12' 39"E
L87	48.36	S81° 22' 03"W
L88	150.02	N9° 29' 19"W
L89	42.64	N81° 22' 03"E
L90	127.14	S8° 04' 31"E
L91	27.29	S24° 26' 44"W
L92	29.60	S81° 22' 03"W
L93	150.02	N9° 29' 19"W
L94	47.97	N81° 22' 03"E
L95	17.59	N40° 27' 23"W
L96	121.23	N9° 12' 33"W
L97	31.26	N85° 30' 41"E
L98	124.10	S9° 29' 19"E
L99	31.83	S81° 22' 03"W

CURVE #	LENGTH	RADIUS	DELTA	CHORD DIRECTION	CHORD LENGTH
C1	54.26	100.00	31°05'08"	N13° 32' 59"E	53.59
C2	6.70	100.00	3°50'12"	S9° 39' 02"E	6.69
C3	86.66	100.00	49°39'03"	S23° 13' 51"E	83.97
C4	64.68	100.00	37°03'37"	N6° 34' 09"E	63.56
C5	67.90	100.00	38°54'19"	N23° 43' 22"W	66.61
C6	55.61	100.00	31°51'46"	N2° 29' 26"E	54.90
C7	49.98	100.00	28°38'07"	N18° 48' 39"W	49.46
C8	35.43	100.00	20°17'54"	N4° 39' 24"W	35.24
C9	35.58	100.00	20°22'18"	N15° 11' 51"W	35.37
C10	45.95	100.00	26°19'42"	N0° 11' 58"W	45.55
C11	2.43	100.00	1°23'40"	N19° 50' 31"W	2.43
C12	34.45	100.00	19°44'21"	N14° 24' 08"W	34.28
C13	94.39	100.00	54°05'02"	S0° 52' 01"E	90.93
C14	41.35	75.00	31°35'07"	N9° 00' 01"E	40.82
C15	16.51	10.00	94°34'20"	S42° 46' 56"W	14.70
C16	19.74	100.00	11°18'43"	S17° 19' 09"W	19.71
C17	52.32	5684.58	0°31'39"	N4° 46' 03"W	52.32
C18	150.05	5684.58	1°30'44"	N5° 53' 17"W	150.04
C19	158.89	5684.58	1°36'05"	N7° 32' 45"W	158.88
C20	103.29	5684.58	1°02'28"	N8° 58' 05"W	103.29
C21	14.84	10.00	85°00'00"	S51° 59' 19"E	13.51